

NewNight LED-Ground recessed spotlight LS12T

High-quality LED ground recessed spotlights for a nice ambiance on paths, driveways or forecourts

For a stylish and efficient street lighting, we recommend the newly developed LED ground recessed spotlight LS12T. The approximately 23 cm wide floor lamp convinces with a high-quality polished stainless steel ring and with clear single-pane safety glazing. The robust spotlight withstands a load of up to 2.5 tons.

The aluminum housing hides a swiveling LED module with its lenses directed light and various light distributions are possible. The built-in LEDs have a particularly long life of > 50,000 h and emit for instance in warm white with a light color of 3,000 K. But other light colors are available, such as the warm-orange [light color amber](#). Facades or selected parts of buildings, but also places can be effectively illuminated.

With IP68 protection in the LED room and IP67 in the power supply, the spotlight is also dust-proof, weather-resistant, therefore, ideally suited for outdoor use.

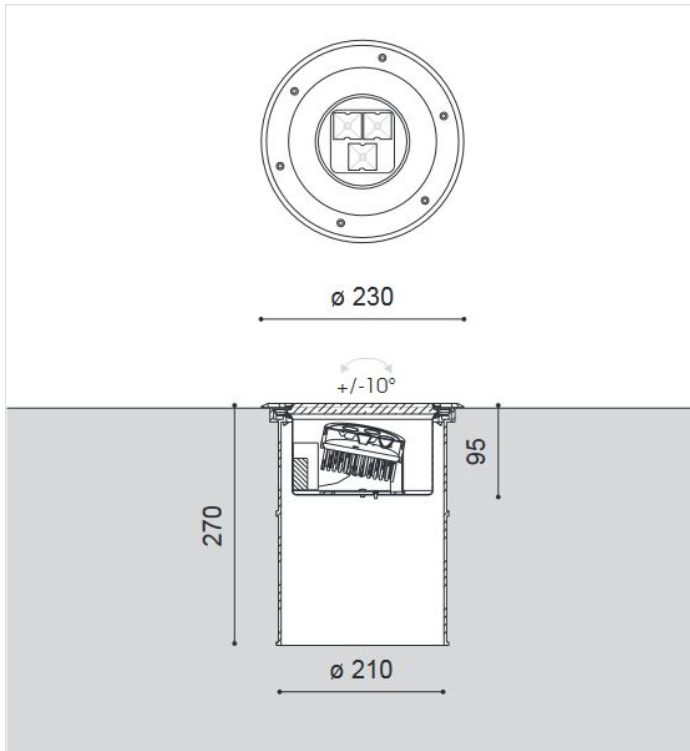

BRAUN – simply better light.

Data sheet:
[LED-Ground Recessed Luminaire LS12T_EN](#)